

## qpod<sup>®</sup> Temperature-Controlled Sample Compartment for Fiber Optic Spectroscopy

*DNA melting and annealing, protein thermodynamics, fluorophore characterization, enzyme kinetics and on-line thermocycling of biological particles... The qpod provides rapid and precise temperature control for fiber optic spectroscopy from -30 °C to +105 °C.*



The **qpod<sup>®</sup>** is a complete sample compartment for fiber optic spectroscopy, including a Peltier-controlled cuvette holder with magnetic stirring, and fused silica lens systems with SMA fiber optic connectors. Combine the qpod with a fiber optic-based light source and a detector, and get a powerful spectroscopy system for a fraction of the cost of a traditional bench top spectrometer.

**Figure 1** - qpod<sup>®</sup> set up for polarized fluorescence measurements

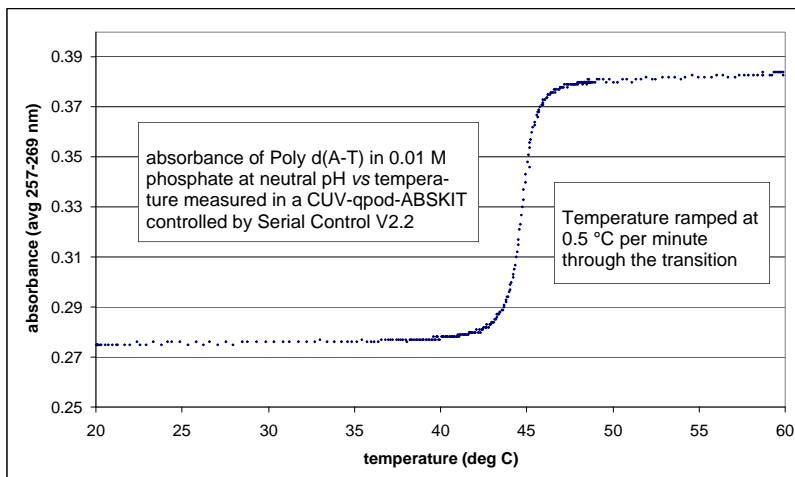
Three standard configurations:

- CUV-qpod-ABSKIT - for absorbance, transmittance or turbidity measurements
- CUV-qpod-FLKIT - for excitation and detection of fluorescence emission at right angles
- CUV-qpod-MPKIT - a multipurpose kit for either absorbance or fluorescence measurements

**Figure 2** - Thermal melting of a synthetic DNA performed with three linear temperature ramps using a qpod<sup>®</sup>

*If you do not control the temperature of your sample, will you get the same result the next time?*

*If you do not know how your sample responds to temperature, what have you missed?*



## Description

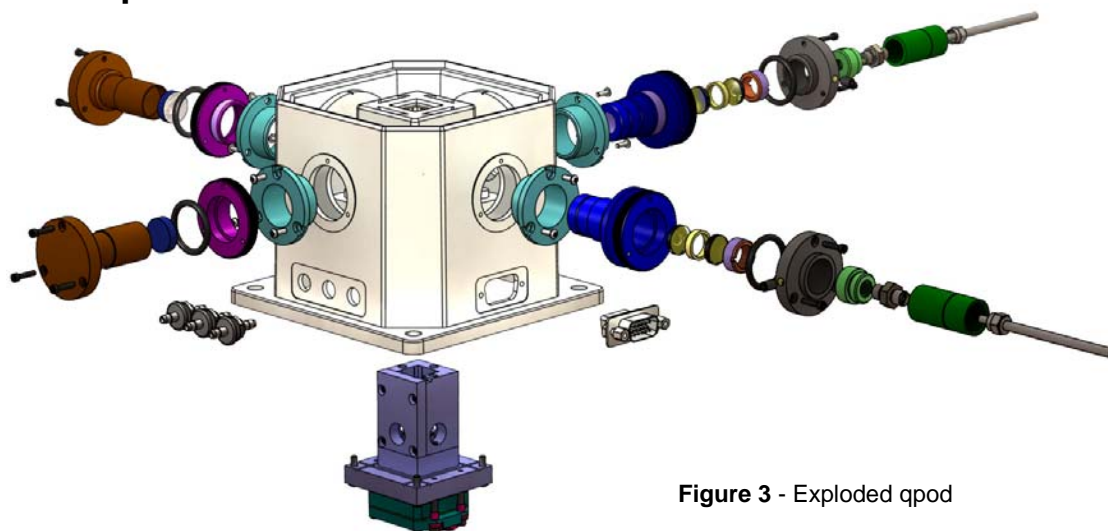


Figure 3 - Exploded qpod

The **qpod**<sup>®</sup> is constructed of a single molded housing. A Peltier-controlled cuvette holder in the center provides temperature control and variable speed magnetic stirring, and holds optical slits for limiting light access to the cuvette as needed. A dry gas purge may be used to minimize condensation when working at low temperatures. SMA fiber optic connections and high quality fused silica optics are inserted in different combinations into optical ports in the walls surrounding the cuvette holder. Accessories such as polarizers and filter holders may be inserted in the light paths. Spherical mirrors may be used to enhance excitation or emitted light. All optics provide focusing and position adjustments for maximizing signal throughput.

For **absorbance** or transmittance measurements, insert two collimating lenses on opposite sides of the **qpod**<sup>®</sup>. The first takes the excitation light from the source and collimates it into a parallel beam about 4 mm in diameter. The beam passes through the sample to be collected by the second collimating lens and focused on the end of the collection fiber, which passes the light to the spectrometer.

To measure **fluorescence** at 90°, insert imaging lenses on adjacent sides of the **qpod**<sup>®</sup>. The first takes the excitation light and focuses it down to form an image (at about 1:1 magnification) of the end of the fiber into the center of the cuvette. The second imaging lens collects fluorescence by imaging the center of the illuminated volume onto the end of the collection fiber. Front surface spherical mirrors may be placed opposite the excitation and emission to enhance the signal.

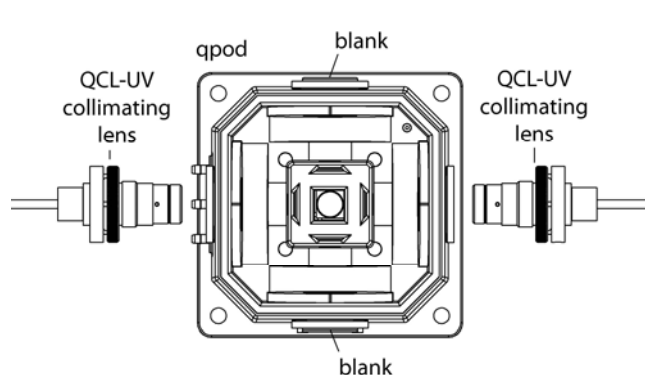


Figure 4 - setting the qpod<sup>®</sup> up for absorbance measurements (see the CUV-qpod-ABSKIT)

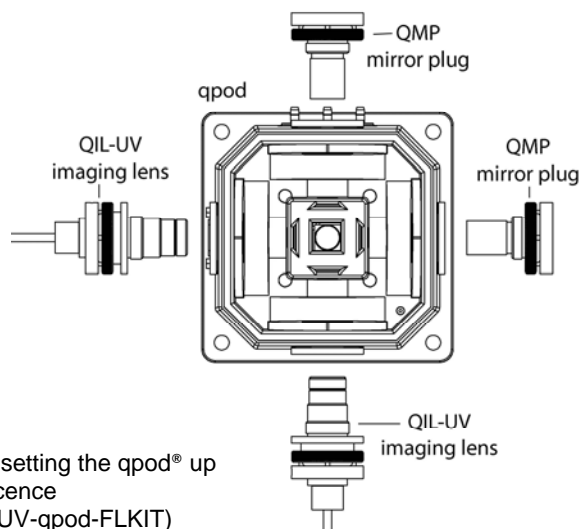


Figure 5 - setting the qpod<sup>®</sup> up for fluorescence (see the CUV-qpod-FLKIT)

# The Temperature Controller



Each qpod® includes a temperature controller, matched to the qpod and calibrated against a NIST-traceable thermometer. Set a target temperature, control the stirring speed and turn temperature control on and off. The TC 125 accepts an external temperature probe that may be used to monitor the temperature of the sample. Standard 400 or 500 series probes are available from several sources.

Figure 6 - TC 125 Temperature Controller

## Optional Serial Control

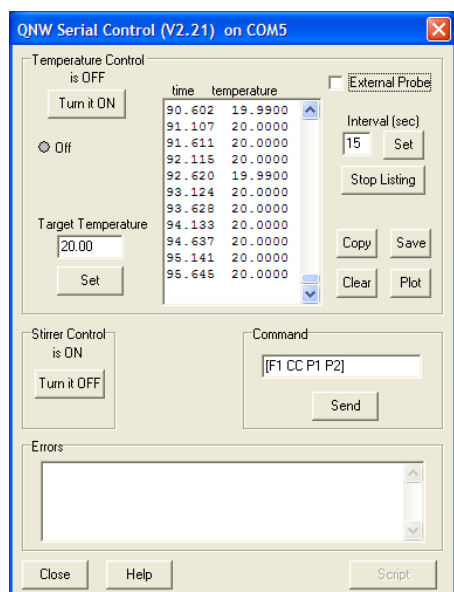


Figure 7 - SER 2.2 main window

If you purchase the additional SER 2.2 option, the TC 125 Temperature Controller may be controlled by an external computer via a USB. SER 2.2 includes a Windows program, QNW Serial Control, whose main window is displayed in Figure 7. From this window, you may set target temperatures, turn temperature control or magnetic stirring on or off, or collect time and temperature data in its main window for both the probe and sample holder temperatures.

A click on the Script button in the lower right corner brings up the Special Tools window shown in Figure 8. Use this window to load a script file, a series of text commands that perform complex temperature functions such as temperature ramping. Sample scripts are provided.

Copy data from the main window onto the clipboard so that it may be used in other applications, or click on the plot button on the main window to bring up a plot of the time and temperature data such as that shown in Figure 9.

Figure 8 - Special Tools window

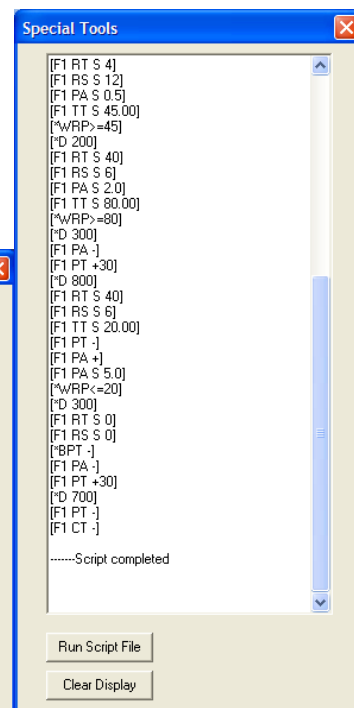
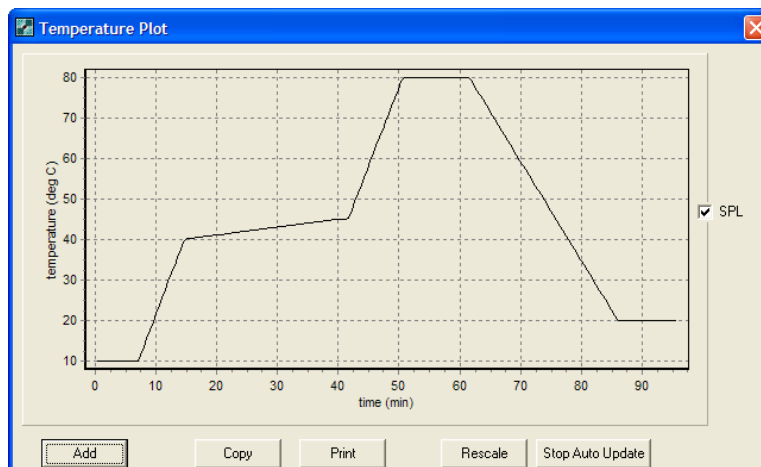


Figure 9 - temperature plot window

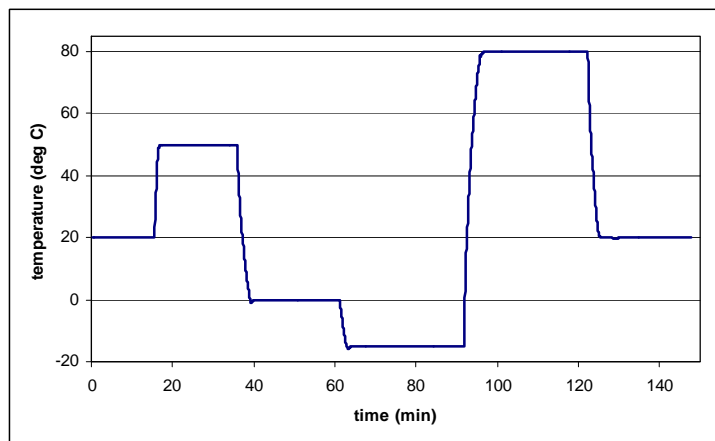
This ramp was used for Figure 2.



---

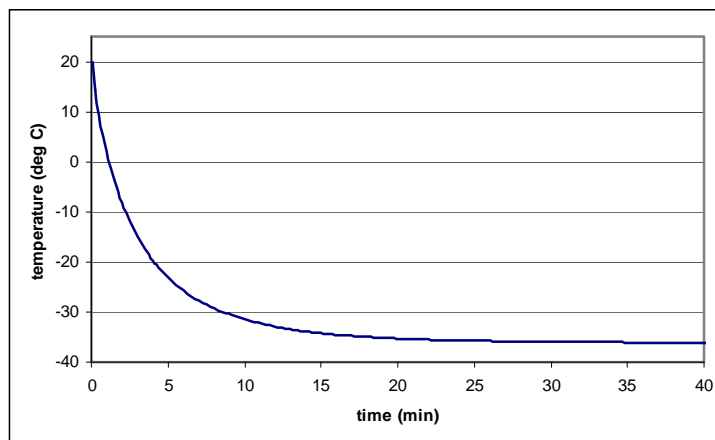
## qpod<sup>®</sup> Temperature Performance

After the temperature calibration procedure is completed, each qpod is put through a performance run and the data included in the manual. **Figure 10** shows an example of such a run. Using script control and the Serial Control program, the qpod<sup>®</sup> is instructed to set and hold the temperature sequence 20.00, 50.00, 0.00, -15.00, 80.00, and 20.00 °C. Note the rapid changes in temperature, stable holding temperatures and very little overshoot. These are the temperatures of the sample holder. Temperatures inside a cuvette would be expected to lag behind as the cuvette comes to equilibrium.



**Figure 10** - qpod temperature performance plot

To examine the low temperature performance of a qpod<sup>®</sup>, ice water was used in the circulating bath and the temperature set to the lowest possible setting, -55.00 °C. Note in **Figure 11** the rapid drop in temperature, falling well below the -30 °C specified minimum temperature. To work at even lower temperatures, use a refrigerated circulating bath containing ethylene glycol- or methanol-water mixtures, cooled to within 25 or 30 °C of the lowest temperature you wish to achieve. A small amount of added foam or bubble wrap inside the qpod around the cuvette holder may help for very low temperature work.



**Figure 11** - qpod low temperature performance

---

## DNA Melting Exercise

Poly d(A-T), a simple model double-stranded DNA, was purchased from the Midland Certified Reagent Company and prepared at a concentration of 16  $\mu$ M base pairs in 0.01 M phosphate at neutral pH. Ethidium bromide was from Sigma Chemical Company.

Due to base stacking, double-stranded DNA has a lower absorbance than single-stranded DNA, a property known as Hypochromism. Melting of the double-stranded structure thus results in an increase in absorbance. Hypochromism provides a simple absorbance test using the qpod for the melting or breakup of the DNA double-helical structure.

The dye, ethidium, intercalates between base pairs of double stranded DNA. When intercalated, the ethidium has a strong fluorescence, whereas free in solution it fluoresces much less. Thus, melting of DNA with intercalated ethidium will eliminate binding sites and result in a large decrease in fluorescence. Thus, ethidium fluorescence provides us with a simple fluorescence test of DNA melting.

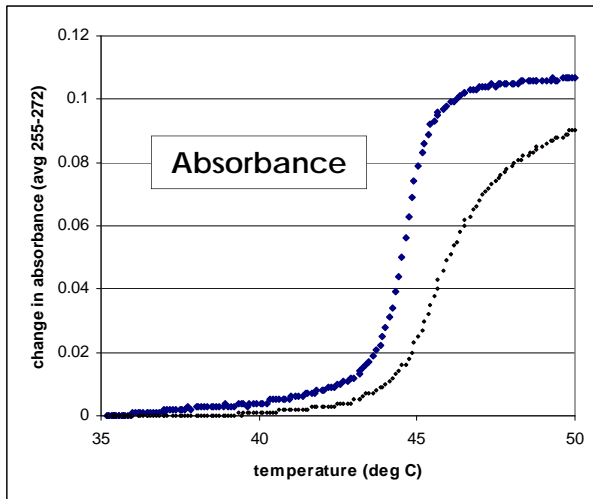
## DNA Melting Exercise (continued)

### Absorbance

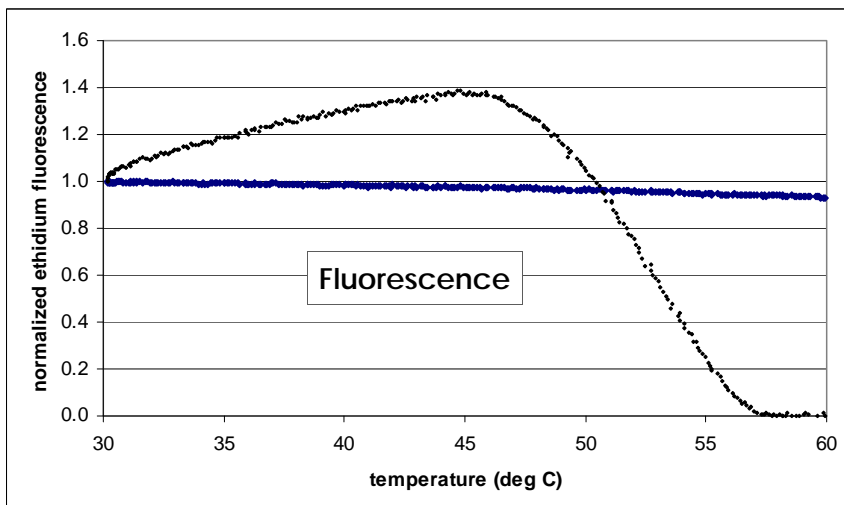
Excitation light for the **qpod**<sup>®</sup> was provided with an Ocean Optics Mini-D2T UV Source and a 300  $\mu\text{m}$  diameter fused silica fiber to a **CUV-qpod-ABSKIT**. Transmitted light was passed through a second 300  $\mu\text{m}$  fiber to an Ocean Optics USB 2000 spectrograph. Using the SER 2.2 Serial Control option, the temperature of the **qpod** was ramped from 35 to 50  $^{\circ}\text{C}$  at a rate of 1  $^{\circ}\text{C}/\text{minute}$ . Absorbance data (blue points) were averaged over the wavelength range of 255 to 272 nm. Note in **Figure 12** the sharp melting transition with a midpoint just under 45  $^{\circ}\text{C}$ . Ethidium was added to a poly d(A-T) solution to a concentration of 0.45  $\mu\text{M}$ , or about one ethidium to 36 base pairs. Note also that the ethidium stabilized the DNA double helix, shifting the curve to a higher temperatures.

### Fluorescence

Ethidium fluorescence was excited using an LS-1 Ocean Optics Visible Source and a 300  $\mu\text{meter}$  fiber connected to a **CUV-qpod-FLKIT**. Visible excitation was isolated to a 450 to 550 nm band using 450 long pass filter and 550 short pass filters mounted in a **QFH** filter holder in the **qpod**<sup>®</sup>. Emitted fluorescence was conducted via a second fiber to an Ocean Optics HR 4000 High Resolution Spectrometer, and averaged from 560 to 700 nm.


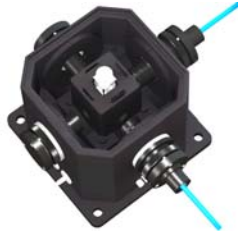



**Figure 12** - Hypochromism changes in poly d(A-T) on melting without (blue) and with (black) ethidium



**Figure 13** - Fluorescence of ethidium alone (blue) and ethidium in the presence of poly d(A-T)

## Packages available for specific applications

product	components	image
<b>CUV-qpod-ABSKIT</b> Absorbance	<ul style="list-style-type: none"> <li>• qpod® Sample Compartment</li> <li>• TC 125™ Temperature Controller</li> <li>• two QCL-UV Collimating Lenses</li> </ul>	
<b>CUV-qpod-FLKIT</b> Fluorescence	<ul style="list-style-type: none"> <li>• qpod® Sample Compartment</li> <li>• TC 125™ Temperature Controller</li> <li>• two QIL-UV imaging lenses</li> <li>• two QMP mirror plugs</li> </ul>	
<b>CUV-qpod-MPKIT</b> Absorbance and Fluorescence	<ul style="list-style-type: none"> <li>• qpod® Sample Compartment</li> <li>• TC 125™ Temperature Controller</li> <li>• two QCL-UV collimating lenses</li> <li>• two QIL-UV imaging lenses</li> <li>• two QMP mirror plugs</li> </ul>	

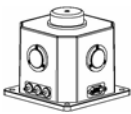


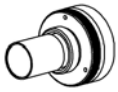



Each qpod® sample compartment is provided with:

- **Quantum Northwest TC 125™ Temperature Controller**
- **circulating pump**, bucket and fittings to provide circulating water to the Peltier unit
- **temperature calibration certificate**
- **tool kit** containing a hex screw driver for optical adjustments, a stir bar for use in the cuvette, a set assorted optical slits to limit optic access to the cuvette, and plastic blanks to cover unused optical ports on the qpod



## Components available individually

Use the following components to add to an existing package, or to assemble a system that has exactly the components you wish.

model number	description	image
qpod®	qpod sample compartment and temperature controller without optics	
QCL-UV	AR-coated fused-silica collimating lens with SMA 905 fiber optic connector and fiber optic steering plate	
QIL-UV	AR-coated fused-silica imaging lens doublet with SMA 905 fiber optic connector and fiber optic steering plate	
QMP	spherical mirror plug with steering plate to enhance excitation or emitted light	
QFH	filter holder for 12.5 mm diameter filter, mounts to a lens assembly	
QPOL-47-215	polarizer for mounting on the QIL-UV lens system, includes an Edmund Optics 47-215 Linear Glass Polarizer	
SER 2.2	serial interface, USB cable and computer program for external computer control, required for complex functions such as ramping and script control	



**Figure 13** - CUV-qpod-FLKIT covered and ready for use

---

## qpod® Feature Summary

- Rapid and precise temperature control from -30 °C to +105 °C ± 0.05 °C
- Designed for standard 1 x 1 cm square cuvettes or standard microcuvettes with a z-height of 8.5 mm (distance between the height of the optical center line and the bottom of the cuvette)
- Variable speed magnetic stirring to maintain uniform temperature in the cuvette
- Dry gas purge to reduce condensation when working at low temperatures
- Light tight cover with access cap providing a means of holding a thermistor probe in the cuvette
- Collimating optics available for straight through absorbance measurements
- Imaging optics available for efficient excitation and light collection for fluorescent samples
- Spherical mirror plugs available for enhancing excitation or emitted light
- All optical components with focusing and position adjustments to maximize light throughput
- Optical slits provided for limiting light access to the cuvette as needed
- Optional filter holders for 12.5 mm diameter filters (25 mm filters may be used without holders.)
- Optional polarizer
- Input jack on temperature controller to accept a thermistor probe for measuring sample temperature
- Optional Window-based software available for computer control of the temperature controller

These products available through the world-wide distributor network of:

*Ocean Optics, Inc.*  
Dunedin, FL, USA  
727-733-2447 or [www.oceanoptics.com](http://www.oceanoptics.com)

Let Ocean Optics integrate the **qpod®** into a complete temperature-regulated spectroscopy system with light sources, fibers, spectrographs and detectors.



QUANTUM  
N • O • R • T • H • W • E • S • T

22910 E Appleway Avenue, Suite 4 · Liberty Lake, WA 99019-8606 · phone: 509-624-9290 · fax: 509-624-9488 · e-mail: [quantum@qnw.com](mailto:quantum@qnw.com)

[www.qnw.com](http://www.qnw.com)

12/11/08